

THIS DRAWING IS UNPUBLISHED. RELEASED FOR PUBLICATION, 19
 © COPYRIGHT 19 BY AMP INCORPORATED. ALL INTERNATIONAL RIGHTS RESERVED.

LOC	DIST	P	F	REVISIONS			DATE	APPD
AF	50			ZONE	LTR	DESCRIPTION		
					K	REV PER 0G1A-0145-99	3JUN99	JR/JH

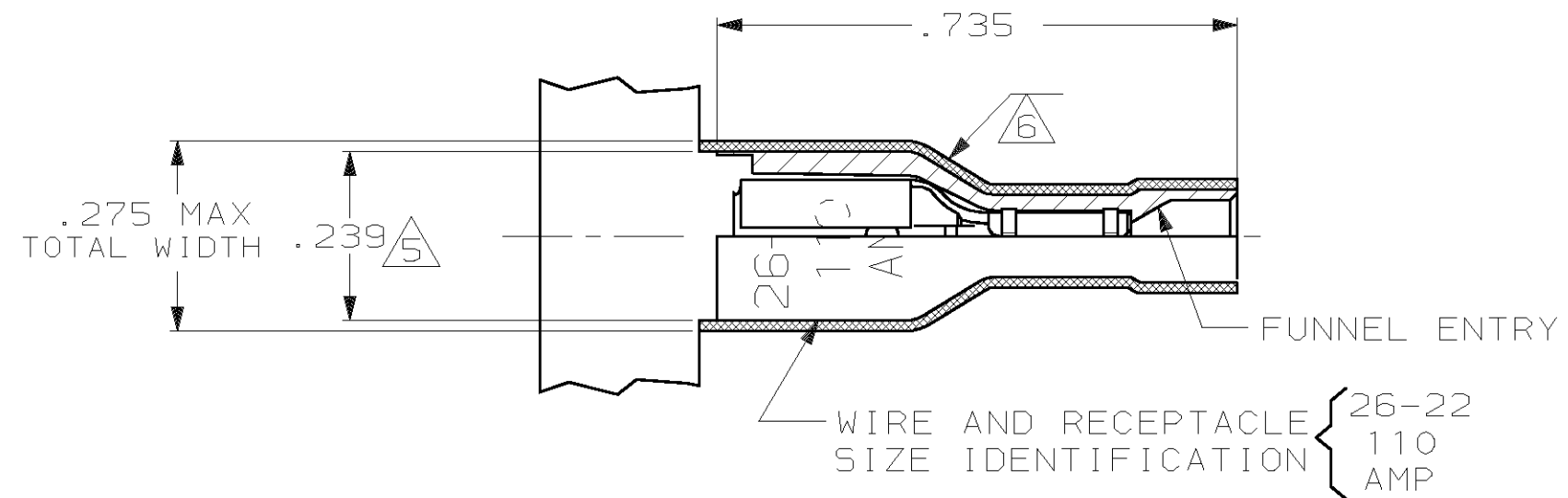

- 1 MATES WITH .020±.001 X .110 OR .125 TABS.
- 2 WIRE STRIP LENGTH .281
- 3 INSULATION SIZE .100 MAX DIA
- 4 CONTINUOUS STRIP ON REELS
- △5 DIMENSION DOES NOT INCLUDE TRIM BURR
- △6 .015 MAX CARRIER TRIM BURR PER SIDE IS ALLOWABLE IN THE SHADED AREA

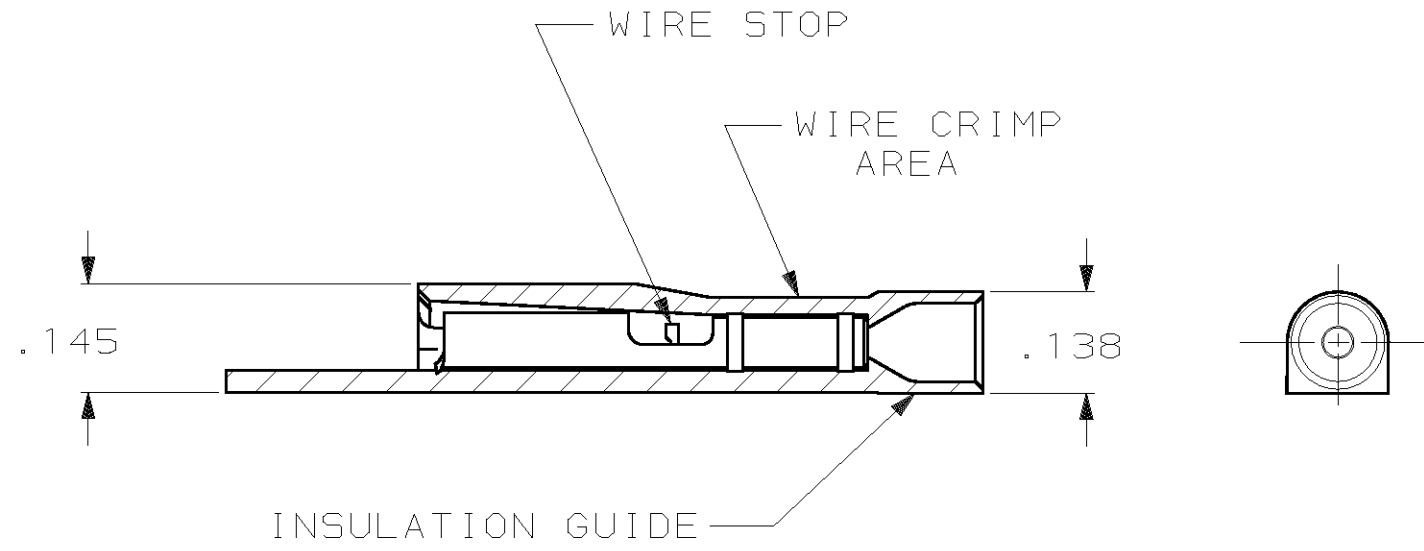
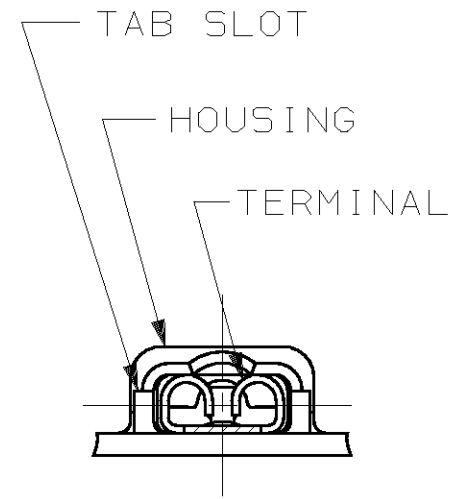

HOUSING: NYLON, COLOR-VIOLET TINT		7-520365-2	
RECEPTACLE: #3 HARD BRASS, TIN .000080 MIN		PART NO	
DO NOT SCALE PRINT. UNLESS SPECIFIED DIMENSIONS IN INCHES TOLERANCES ON: 2 PLC DEC ± - 3 PLC DEC ± .015 ANGLES ± -		DR 11/14/88 P FORTNEY	AMP INCORPORATED Harrisburg, Pa. 17105
MATERIAL SEE TABLE	CHK 11/15/88 MS FEHER	APPD 11/15/88 K RANDOLPH	
FINISH SEE TABLE	APPD 11/15/88 TL SHUTTER	PRODUCT SPEC 108-2043	NAME RECEPTACLE ASSY, ULTRA-FAST, .110/.125 SERIES, 26-22 AWG
	APPLICATION SPEC 114-2123	SIZE B	FSCM NO 00779
	WEIGHT -	SCALE 4:1	DRAWING NO 520365
			SHEET 1 OF 1